

Use the following instructions to replace the cartridge in Shure Beta 87 condenser microphones.

1. Remove the microphone grille by unscrewing it in a counterclockwise direction.

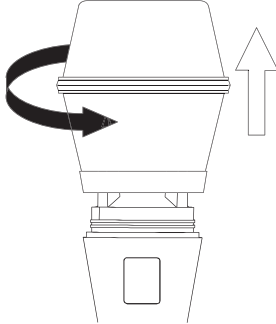

2. Using tweezers or small needle-nosed pliers, grasp the pins at the end of the blue and green leads and gently unplug them from the cartridge.

CAUTION: Be careful when handling the lead wires, as they may easily come loose from the pins.

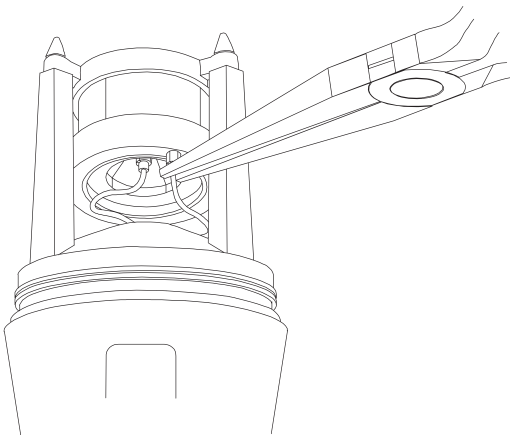

3. Remove the old cartridge by pulling off the rubber loops from the three shock-mount posts.

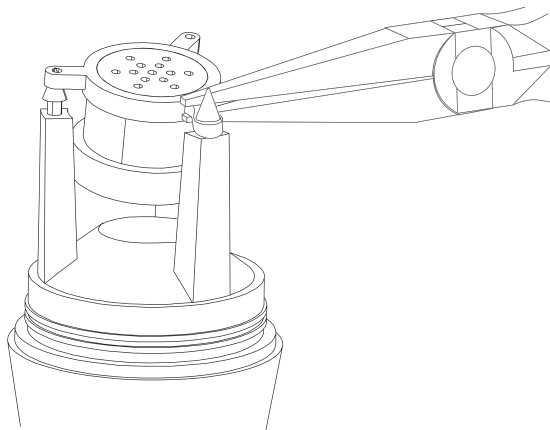

4. Attach the pins of the two leads to the sockets in the cartridge base. The green lead matches the center socket and the blue lead matches the outer socket.
5. Install the new cartridge by slipping the rubber loops over the shock-mount posts.

IMPORTANT: Align the pin sockets as illustrated below.

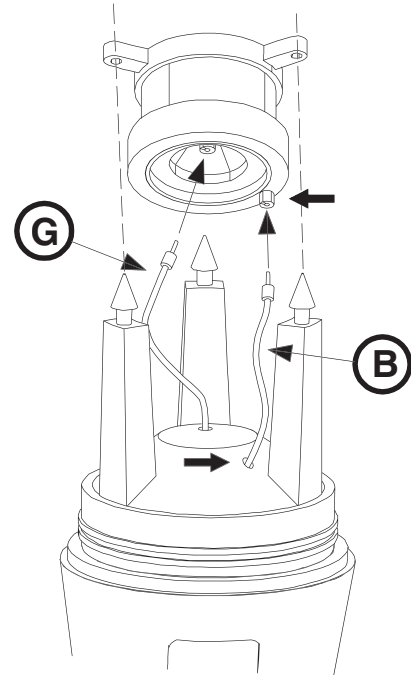

IMPORTANT: Once you have installed the cartridge, take care to position the blue end and green lead wires so they do not touch each other, the cartridge and any other part of the microphone. Otherwise, noise problems may occur.

SHURE®

SHURE Incorporated <http://www.shure.com>
United States, Canada, Latin America, Caribbean:
5800 W. Touhy Avenue, Niles, IL 60714-4608, U.S.A.
Phone: 847-600-2000 U.S. Fax: 847-600-1212 Int'l Fax: 847-600-6446
Europe, Middle East, Africa:
Shure Europe GmbH, Phone: 49-7131-72140 Fax: 49-7131-721414
Asia, Pacific:
Shure Asia Limited, Phone: 852-2893-4290 Fax: 852-2893-4055

